

3-Channel Low-Dropout Constant-Current Parallel LED Driver with PWM Dimming Control

General Description

The CP2139, a 3-channel low-dropout constant-current parallel LED driver, can be used to drive white LED, red LED, blue LED or any color LED whose forward operating voltage is lower than the battery voltage. The unique Auto-Mirror™ technology is introduced in CP2139, which can guarantee a constant LED current in various operating conditions. With the PWM signal on the EN pin, the brightness of LED can be adjusted by the duty cycle. Without any external components, it is available in a tiny SOT23-6L package and is ideally suitable for portable device applications.

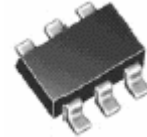

SOT23-6L

-40°C~85°C

Features

- No External Component Required
- 20mA Full Scale Current per Channel
- Only 100mV Dropout Voltage Needed at 20mA per Channel
- LED Current Matching: $\pm 2\%$ (typical)
- PWM Dimming Control is Supported (0~100kHz)
- Over 90% Efficiency can be Reached
- No EMI and Switch Noise
- Thermal Shutdown Protection
- Supply Voltage Range: 2.7~5.5V
- Shutdown Current Less Than 0.1 μ A
- RoHS Compliant and 100% Lead(Pb)-free

Applications

- Mobile Phones
- Digital Still Camera
- MP3 Players
- PDA
- GPS Receivers

Pin Configuration

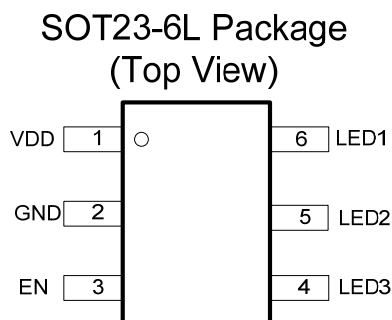

SOT23-6L Marking



CPLVG-CP2139ST

3-Channel Low-Dropout Constant-Current Parallel LED Driver with PWM Dimming Control

Typical Application Circuits

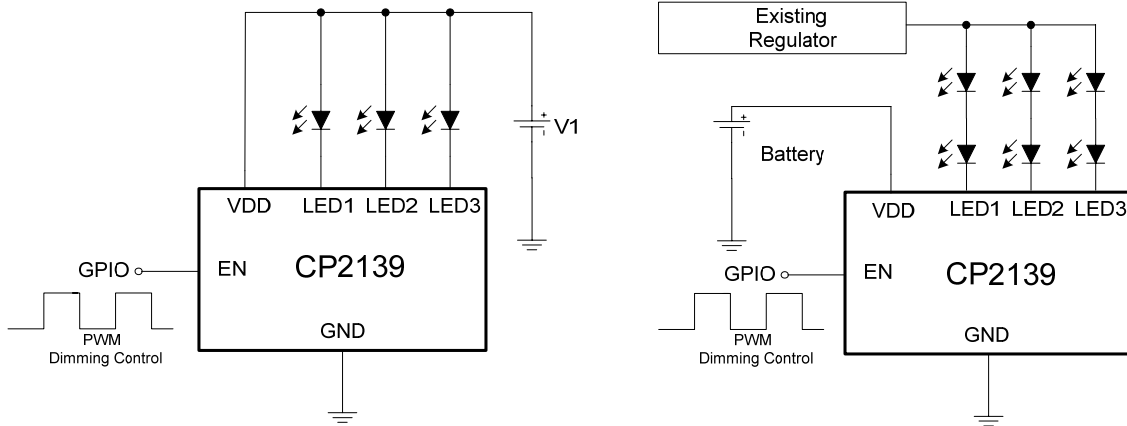

Contact with Chiphomer

4F, Building D, 1618 Yishan Road Shanghai, 201103, P.R.C.
 Tel: (86)21-64014543 64058488
 Fax: (86)21-64050030
 Sale: sales@chiphomer.com
 Technical support: support@chiphomer.com
 Web site: www.chiphomer.com

Shenzhen Office:
 10D, Building 2, Dushi Yangguang Garden CheGongMiao, Futian District, Shenzhen, 518048, P.R.C.
 Tel: (86)755-82046706 82047789
 Fax: (86)755-8204670